

FR1200 Series

UHP High-Flow, Tied Diaphragm, Single Stage Pressure Reducing Regulator



Precise Control, High Flow Performance

The FR1200 Series ultra high purity, pressure reducing regulator offers high-flow capability with an inlet pressure up to 1700 psig and is an excellent choice for point of use bulk and specialty gas applications.

The large, tied Hastelloy C-22[®] diaphragm provides stable control over its full operational range while providing a robust seal for hazardous gas applications.



Contact Information:

Parker Hannifin Corporation
Veriflo Division
250 Canal Blvd
Richmond, California 94804

phone 510 235 9590
vfo.quotes@support.parker.com
vfo.support@support.parker.com

www.parker.com/veriflo
Mobile App: m.parker.com/veriflo

Product Features:

- 316L stainless steel body
- Passivated & Electropolished
- Manufactured for ultra high purity semiconductor gas applications
- Tied diaphragm design
- Metal-to-metal diaphragm seal
- Hastelloy C-22[®] diaphragm
- 10 μ in. Ra surface finish
- Flows up to 1200 slpm (42 scfm)



ENGINEERING YOUR SUCCESS.

FR1200 Series

Flow Curves

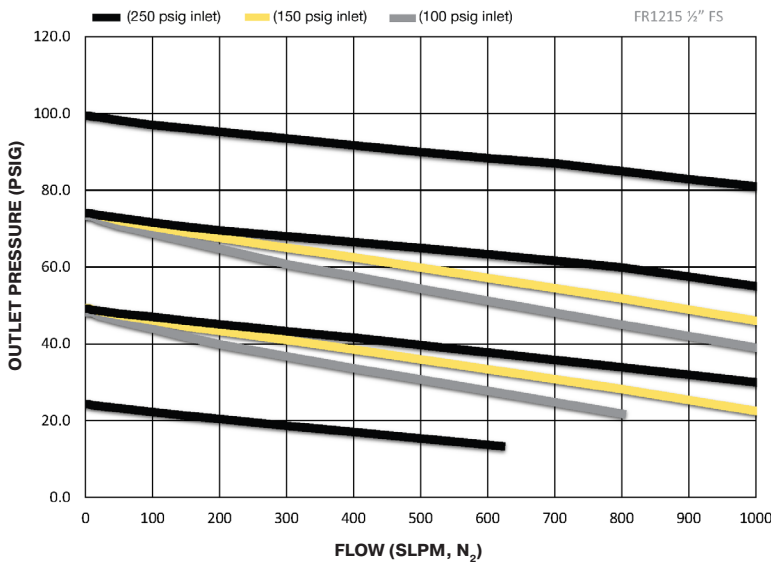
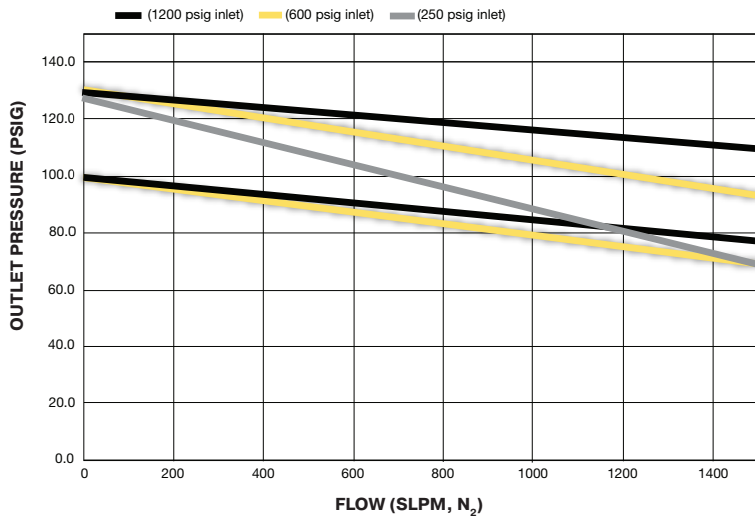

Additional flow curves available upon request

Dimensional Drawings

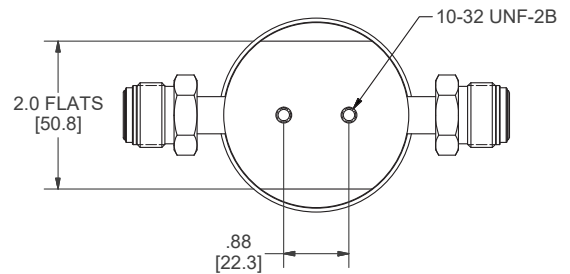
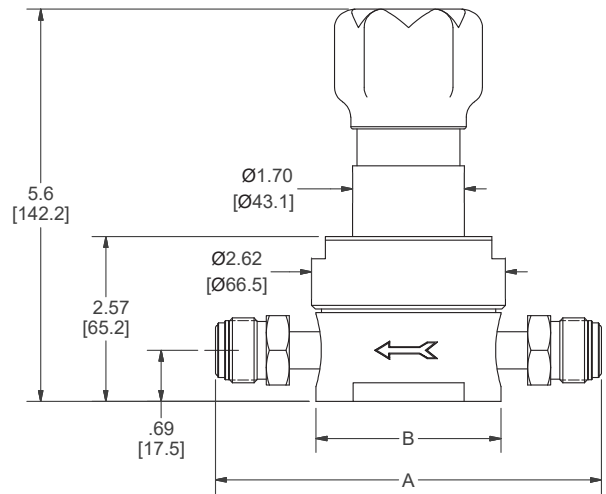

All dimensions in inches. Metric dimensions are for reference only.

Porting Configurations

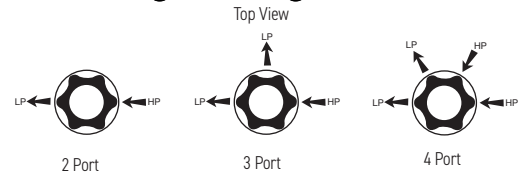

DIMENSION TABLE			
Body Style	Connection Type	End to End Dimension (A)	Body Diameter (B)
Single Melt*	1/4" Face Seal (male & female)	4.30 in. [109.2 mm]	Ø2.50 in. [63.5 mm]
	1/4" Face Seal (female)	3.70 in. [94.0 mm]	Ø2.38 in. [60.5 mm]
Double Melt	1/4" Face Seal (male)	4.00 in. [101.6 mm]	Ø2.38 in. [60.5 mm]
	1/4" Tube Stub	3.46 in. [87.9 mm]	Ø2.38 in. [60.5 mm]
Single/Double Melt	3/8" Face Seal	5.22 in. [132.6 mm]	Ø2.50 in. [63.5 mm]
	3/8" Tube Stub	4.00 in. [101.6 mm]	Ø2.50 in. [63.5 mm]
	1/2" Face Seal	5.22 in. [132.6 mm]	Ø2.50 in. [63.5 mm]
	1/2" Tube Stub	4.34 in. [110.2 mm]	Ø2.50 in. [63.5 mm]
Double Melt	3/4" Face Seal	6.26 in. [159.0 mm]	Ø2.50 in. [63.5 mm]
	3/4" Tube Stub	5.00 in. [127.0 mm]	Ø2.50 in. [63.5 mm]

* 1/4" tube stub not offered

Safety Guide and Installation and Operating Instructions available at
www.parker.com/veriflo

FR1200 Series

Ordering Information

Build an FR1200 Series regulator by replacing the numbered symbols with an option from the corresponding tables below.

Contact factory for most up to date lead time information.

Blue = Configurations that have selections in blue will require a price quote and lead time from the factory.

Sample: **FR1215** **H** **S** **12** **K** **4P** **X** **X** **FS6** **FF** **TH**
Finished Order: **FR1215HS12K4PXXFS6FFTH**

1 Basic Series

FR1203 = 1 - 30 psig
FR1206 = 5 - 60 psig
FR1210 = 10 - 100 psig
FR1215 = 15 - 150 psig

2 Source Pressure Range

H = 0 - 1700 psig
L = 0 - 300 psig

** For low inlet pressure applications below 300 psig, specify "L" model for improved droop performance.*

3 Body Material

S = 316L SS
D = 316L SS (Double melt) *

** Captured bonnet with 1/8" FNPT vent port standard with 316L SS double melt body.*

4 Flow Capacity

12 = 1.2 Cv

5 Seat Material

K = PCTFE
V = Polyimide

6 Porting*

2P = 2 Ports
3P = 3 Ports
4P = 4 Ports

** Refer to the Regulator Porting Guide, 25000156, for additional porting*

7 Outlet Gauge*

X = No Gauge
03 = 0 - 30 psig
0L = 0 - 60 psig
01 = 0 - 100 psig
2 = 0 - 200 psig
4 = 0 - 400 psig

** Only include with "3P" or "4P" body configurations.*

8 Inlet Gauge*

X = No Gauge
01 = 0 - 100 psig
4 = 0 - 400 psig
10 = 0 - 1000 psig
20 = 0 - 2000 psig
30 = 0 - 3000 psig
40 = 0 - 4000 psig

** Only include with "4P" body configuration.*

9 Port Style

TS = 1/4" Tube Stub
FS = 1/4" Face Seal
FS6 = 3/8" Face Seal *
TS6 = 3/8" Tube Stub
FS8 = 1/2" Face Seal
TS8 = 1/2" Tube Stub
FS12 = 3/4" Face Seal
TS12 = 3/4" Tube Stub

** Provided with 1/2" face seal nuts.*

10 Port Configuration

M = Male
F = Female
I = Internal Face Seal
(gauge ports only)

** 1/4" FS-M Gauge Ports are Standard
Any other gauge port configuration may have an extended lead time.*

11 Optional Features

This section can have multiple options

Blank = None
PM = Panel Mount
TH = Ni-Cr-Mo alloy poppet
(Hastelloy® or equivalent)

FR1200 Series

Specifications

Wetted Materials of Construction	
Body	316L SS (std), 316L SS Double melt
Diaphragm	Ni-Cr-Mo alloy (Hastelloy® or equivalent)
Poppet	316L SS (std) Ni-Cr-Mo alloy (Hastelloy® or equivalent)
Poppet Spring	Inconel®
Seat Retainer	316L SS (std)
Seat	PCTFE (std), Polyimide
Finish	Passivated & Electropolished

For additional information on materials of construction, functional performance and operating conditions, please refer to Veriflo report RI.EN.RP018.

All specifications subject to change without notice.

Hastelloy® is a registered trademark of Haynes International, Inc.
Inconel® is a registered trademark of Special Metals Corporation

Functional Performance	
Flow Capacity (Cv)	1.2
Internal Leakage (seat)	$\leq 4 \times 10^{-8}$ scc/sec He
External Leakage (Inboard)	$\leq 2 \times 10^{-10}$ scc/sec He
Supply Pressure Effect	6.8 psig / 100 psig
Internal Volume	
1/4" Face Seal	1.02 in ³ (16.7 cm ³) ¹
1/2" Face Seal	1.41 in ³ (23.1 cm ³) ¹
3/4" Face Seal	2.42 in ³ (39.7 cm ³) ¹
Proof Pressure	2,550 psig
Burst Pressure	5100 psig
Approx. Weight	4.3 lbs (2.0 kg)
Operating Conditions	
Maximum Inlet Pressure	300 or 1700 psig ²
Temperature	-40°F to 150°F (-40°C to 65°C)
Mounting	Surface (std)
	Panel (1.75 in. [44.4 mm] hole required)

1. Internal volume includes end connections.
2. Pressure rating based on nominal temperature conditions. Refer to Veriflo report RI.EN.RP018 for specific information regarding regulator performance at temperature.

OFFER OF SALE:

The items described in this document are hereby offered for sale by Parker-Hannifin Corporation, its subsidiaries or its authorized distributors. This offer and its acceptance are governed by the provisions stated in the detailed "Offer of Sale" elsewhere in this document or available at www.parker.com/veriflo



WARNING USER RESPONSIBILITY

FAILURE OR IMPROPER SELECTION OR IMPROPER USE OF THE PRODUCTS DESCRIBED HEREIN OR RELATED ITEMS CAN CAUSE DEATH, PERSONAL INJURY AND PROPERTY DAMAGE. THIS DOCUMENT IS FOR REFERENCE ONLY. PLEASE CONSULT FACTORY FOR LATEST PRODUCT DRAWINGS AND SPECIFICATIONS

This document and other information from Parker-Hannifin Corporation, its subsidiaries and authorized distributors provide product or system options for further investigation by users having technical expertise.

The user, through its own analysis and testing, is solely responsible for making the final selection of the system and components and assuring that all performance, endurance, maintenance, safety and warning requirements of the application are met. The user must analyze all aspects of the application, follow applicable industry standards, and follow the information concerning the product in the current product catalog and in any other materials provided from Parker or its subsidiaries or authorized distributors.

To the extent that Parker or its subsidiaries or authorized distributors provide component or system options based upon data or specifications provided by the user, the user is responsible for determining that such data and specifications are suitable and sufficient for all applications and reasonably foreseeable uses of the components or systems.

The products described herein, including without limitation, product features, specifications, designs, availability and pricing are subject to change by Parker Hannifin Corp and its subsidiaries at any time without notice.

Proposition 65 Warning: This product contains chemicals known to the state of California to cause cancer or birth defects or other reproductive harm.